

BI-METAL THERMOMETER

Size - 4" Model 113 & 114 Series



FEATURES

- Accuracy $\pm 2\%$ of full scale reading.
- Temperature range 0°C 120°C.
- All stainless steel construction for thermometer.
- Brass well optional.
- Resettable maximum temperature indicator.
- UV stabilized, impact resistant poly-carbonate/glass lens.
- Precise and smooth pointer movement.
- High contrast white marking on black background.

VIAT

INSTRUMENTS

CA113-4R0



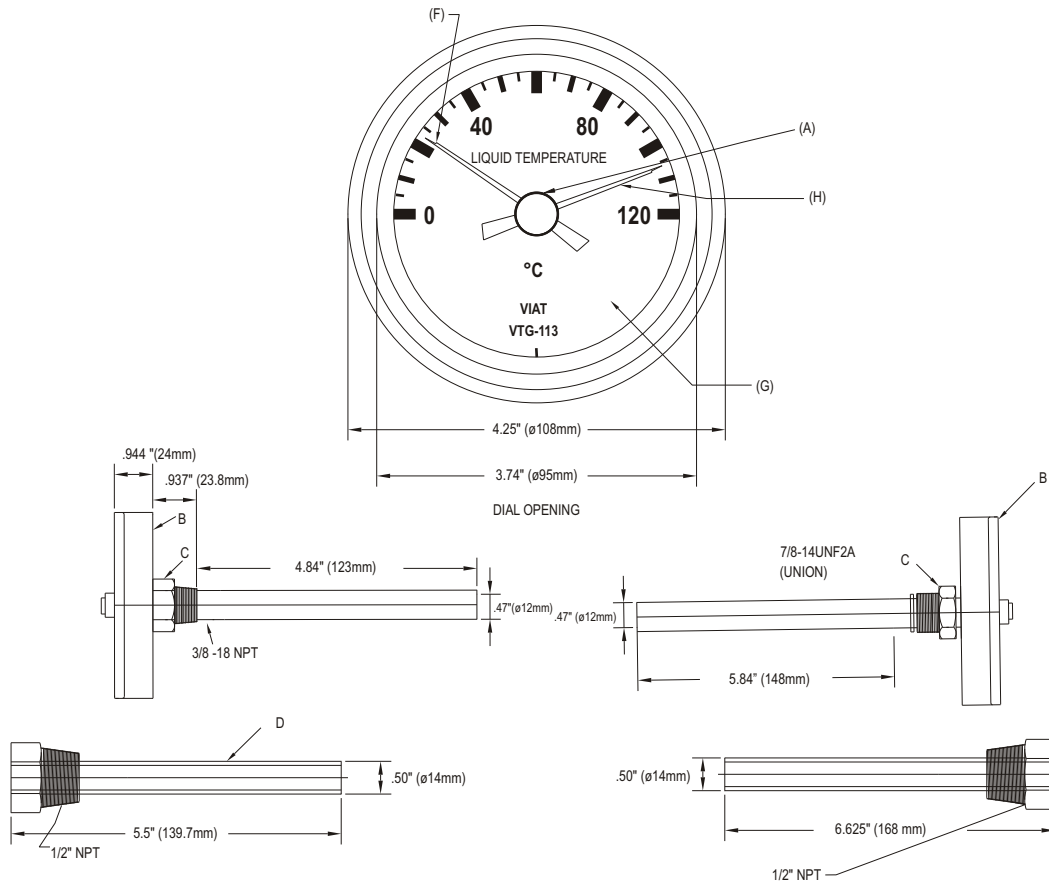

DESCRIPTION

VIAT bimetal thermometers have a rugged construction. The all stainless steel and brass construction allows the thermometers to be used for both indoor and outdoor application. Transparent moulded poly-carbonate lens provides clear visibility and protection to the pointer and dial.

The body with mounting thread and stem is all made of stainless steel. The well is made of brass.

OPERATION & APPLICATION

A bimetal helix element in the stem of the gauge senses the temperature and rotates the pointer on the dial. The pointer indicates the stem temperature on the dial face. The maximum pointer is carried upscale with the indicating pointer. When the indicating pointer moves down the scale in response to lowering temperature, the maximum pointer remains at the same location. The maximum pointer can be reset at any position of dial.

PART LIST

PART NO.	DESCRIPTION	MATERIAL
A	MAXIMUM POINTER SET-SCREW	BRASS / SS
B	BODY	STAINLESS STEEL
C	GLAND FOR FITTING	STAINLESS STEEL
D	STEM	STAINLESS STEEL
E	TRANSPARENT COVER	GLASS / POLYCARBONATE
F	POINTER FOR INDICATING TEMPERATURE	ALUMINIUM
G	DIAL	ALUMINIUM
H	RED POINTER	ALUMINIUM

Due to our policy of continuous product improvement, dimensions and designs are subject to change.



VIAT INSTRUMENTS PVT. LTD.

2701 to 2704, Shilpangan Phase-II, Block LB-1
Sector-III, Salt Lake, Kolkata - 700 098, INDIA
Phones : (91-33) 9903805104, 23352925 ● Fax : (91-33) 23352926
E-mail : viatin@viatin.com ● Website : www.viatin.com

VIAT AMERICA, INC.

30 Shepard, Irvine, CA 92620
Tel: 949-679-0950 Fax: 949-417-1358
E-mail : sales@viatamerica.com
Website : www.viatamerica.com