

LIQUID LEVEL INDICATOR

Model 805 Series



FEATURES

- Suitable for both external and internal mounting.
- Highly visible dial and pointer.
- All Brass and Aluminium components for use in outdoor applications.
- Use of highly transparent poly-carbonate lens with added ultra violet stabilizers.
- Ideal for use in oil filled transformers.
- Strong and rugged construction.
- Working oil temperature of -25°C to 120°C.
- Internal float connected to pointer on the dial through magnetic coupling, eliminating all possibility of leakage.

VIAT

INSTRUMENTS

CA805R0



FRONT VIEW

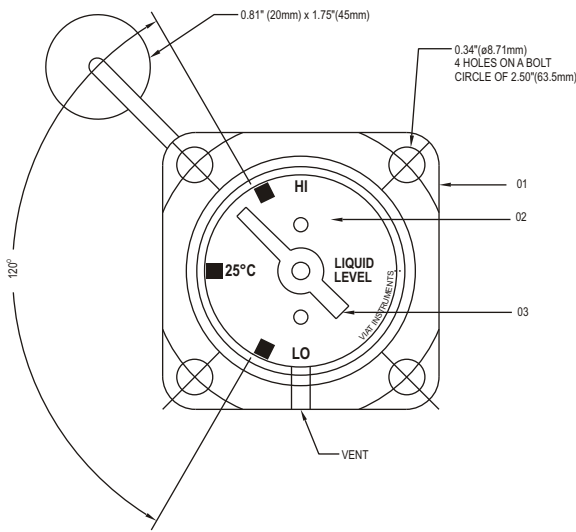

DESCRIPTION

The VIAT 805 serial oil level indicator consists of a square flanged Aluminium die cast body. The float shaft is magnetically coupled with the pointer on the dial. The dial has white marking on a black background thereby providing excellent visibility.

The indicator can be mounted internally by means of thread with brass lock nut. It can also be mounted externally by using 4 bolts on the flange surface. The mounting gasket is supplied. The 805 series level indicator is interchangeable with leading brands available in the market.

OPERATION & APPLICATION

Any movement of fluid in the tank is transferred to the float and shaft. This movement through the magnetic coupling moves the pointer on the dial.

This indicator is ideal for use with oil filled transformers, and is mounted horizontally on the tank or conservator.

SIDE VIEW

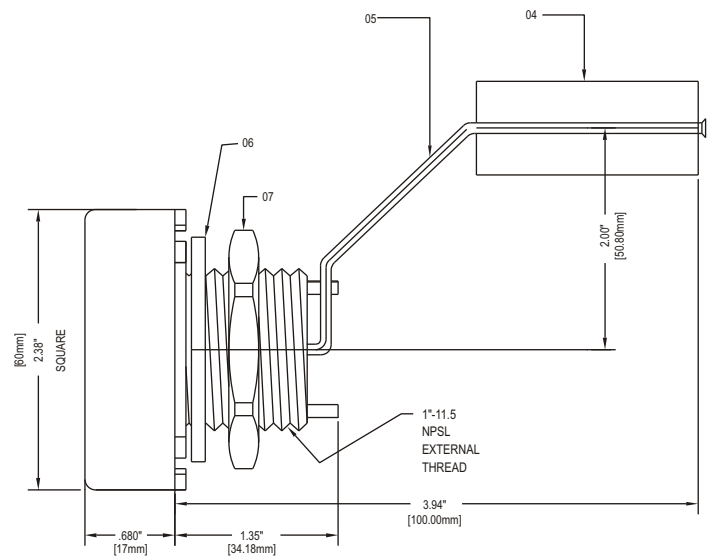

PART LIST

PART NO.	DESCRIPTION	MATERIAL
01	BODY	ALUMINIUM
02	DIAL COVER	UV PROTECTED POLYCARBONATE
03	POINTER	ALUMINIUM
04	FLOAT	EXPANDED POLYURETHANE
05	FLOAT SHAFT	PHOSPHOR BRONZE
06	MOUNTING GASKET	NITRILE BUTADIENE RUBBER
07	NUT	BRASS

Due to our policy of continuous product improvement, dimensions and designs are subject to change.



VIAT INSTRUMENTS PVT. LTD.

2701 to 2704, Shilpangan Phase-II, Block LB-1
Sector-III, Salt Lake, Kolkata - 700 098, INDIA
Phones : (91-33) 9903805104, 23352925 ● Fax : (91-33) 23352926
E-mail : viatin@viatin.com ● Website : www.viatin.com

VIAT AMERICA, INC.

30 Shepard, Irvine, CA 92620
Tel: 949-679-0950 Fax: 949-417-1358
E-mail : sales@viatamerica.com
Website : www.viatamerica.com